

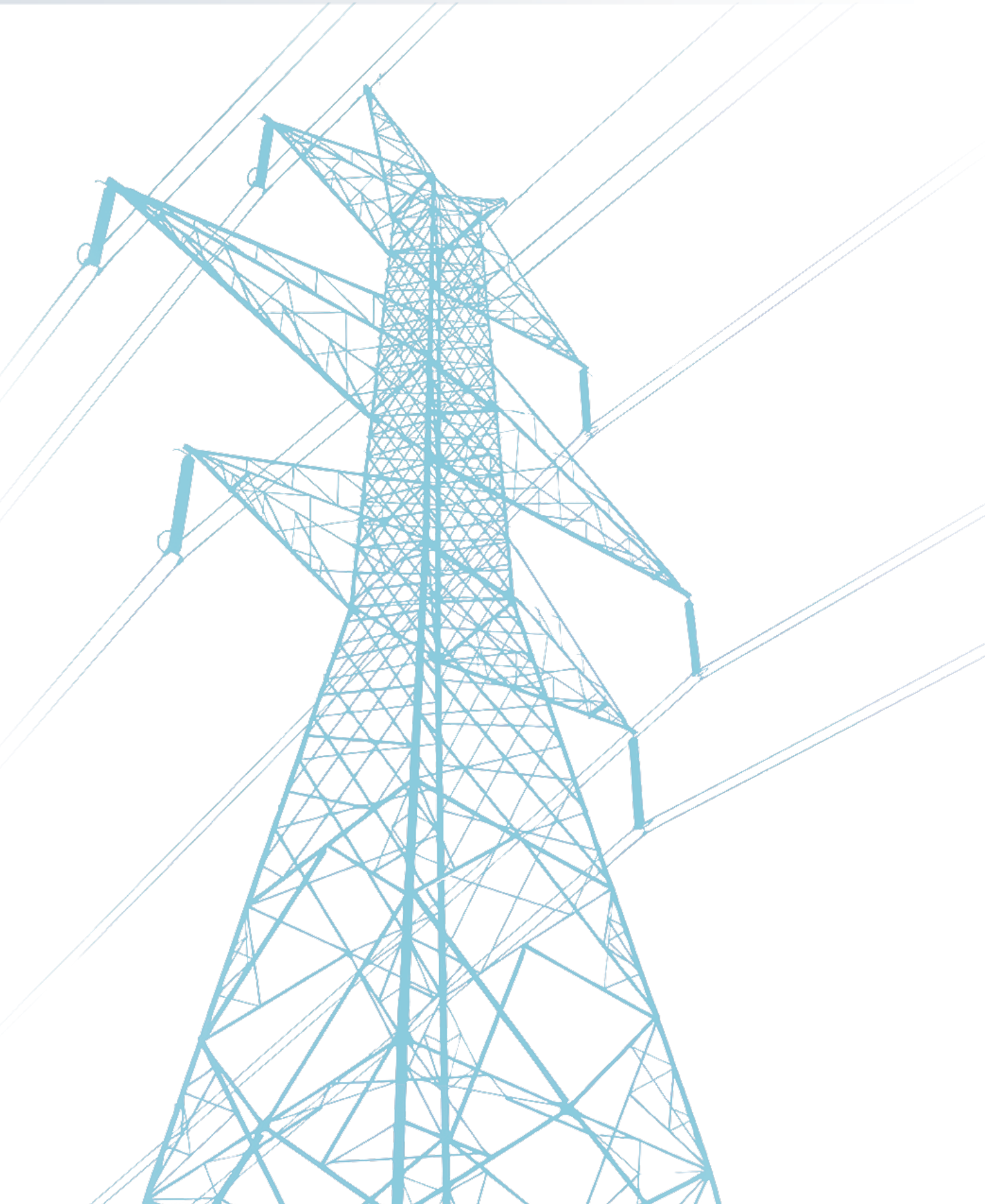

 **UMEK**®  
GLASS INSULATORS





## UMEK JSC

UMEK JSC is a manufacturer of glass insulators for HV lines. UMEK, JSC is a part of a huge Russian industry group FORENERGO.

The construction of the plant began in Yuzhnouralsk (the Chelyabinsk region, Russia). The location of this plant – in the Ural district – was not chosen by coincidence: this district traces its history back to the Demidovs' plants of the 18th century. A huge industrial potential was accumulated here, that is why the first insulator was produced within 2 years in 2009 by the UMEK plant.

Nowadays the production capacity of UMEK is 4 million glass insulators per annum. The plant has got state-of-the-art equipment manufactured by leading global producers. UMEK manufactures more than 60 kinds of insulators that we supply mainly to Russia, Kazakhstan, Uzbekistan, Azerbaijan, Belarus and etc.

We focus more on the quality of produced goods and have got a privately-owned accredited testing laboratory. Moreover, we implemented the international quality management standard ISO 9001:2015. In addition to this, we care for the environment and work in accordance with ISO 14001:2015 and health and safety management system in accordance with OHSAS 18001. Our engineers continuously design new products and improve already utilised types. New developments either improve operational characteristics of the production-line product, or develop new types of insulators, for instance, with increased creepage distance and RTV-coating.





UMEK plant has celebrated its 10 years of successful work in 2017. UMEK is an active partner of the electrical power field: it takes part in local and international exhibitions holding in leading independent testing centres of Russia and Europe.

We are proud of our quality, confirmed by failure-free operation of UMEK glass insulators. Our insulators are used in service of overhead lines with voltage from 10kV to 750kV of electricity grid operating companies of the Euro-Asian region.

UMEK glass insulators are successfully operated in different climate zones, in the harsh region of Continental Arctic, providing electricity supply of oil and gas companies such as GAZPROM, PJSC, ROSNEFT, PJSC, pipelines “Eastern Siberia – Pacific Ocean” and “Power of Siberia”, in addition to this, in warm and wet climate, providing electricity supply of the Olympic objects in Sochi.

We have distinctive capabilities and unique assets with the highest technological content. Our experience and high quality of products allow us to make the best offer in the world market. We suggest long-term reliable business relation and mutually beneficial cooperation.



## Certificates

The quality of production is the important and distinctive characteristic of any product. The improvement of production quality has got a paramount importance and allows the UMEK plant to meet the requirements and expectations of its buyers for implementation of their projects at the highest level.

UMEK pays much attention to the health of its staff and the environment. These are two interconnected things, which always have to meet certain requirements.

Besides, the workplace conditions assessment for compliance with the performance criteria required for the “Achievement Award” is carried out periodically at the enterprise according to the requirements of our customers.

Requirements imposed by our customers have allowed us to develop the most exacting approach to the organisation of production process, employees and the environment, confirmed by available certificates



ISO 9001



ISO 14001



OHSAS 18001

## Insulator components

Cap and pin type suspension glass insulator consists of the following elements: insulating part (or dielectric), pin, cap and locking device.



A locking device is a part of insulator for fixation and is manufactured of stainless steel. The assembling of an insulator is performed by cement-sand mix followed by thermal wet treatment. The assembling may be performed with Portland cement or aluminosilicate cement.

A cap is for movable fixation of an insulator to another one or fittings. Caps are produced by casting from high-strength cast iron or malleable cast iron. Caps have corrosion-resistance coating, made by the method of hot-dip zinc coating. Caps for DC insulators are equipped with a collar made by casting.

The insulating part is manufactured by the compaction method from low-alkali glass followed by toughening. An insulating part might be produced in different shapes, which define the profile of insulator: standard, fog and open.

A pin of insulator is for movable fixation of an insulator to another one or fittings. Insulator's pin is produced from forged steel followed by the application of corrosion-resistant coating. Zinc is of use of corrosion-resistant coating. The method of application is hot-dip galvanizing. The pin has got a ball-shaped head for movable fixation with another insulator or fittings. Pins for DC insulators and pins for pollution and maritime area insulators are equipped with a zinc sleeve made by casting.



## RTV-coating

The usage of glass insulators with RTV - coating has got many advantages:

- the RTV - coating minimises dirt retention of the insulator's surface;
- flashover characteristics are increased;
- the probability of string's flashover even under the conditions of heavy pollution reduces dramatically;
- no need to clean and wash the insulator's string, that's why operation costs of power transmission lines are considerably reduced;
- the radio interference level of insulators and strings in general decrease;
- glass insulators assume the sustainability to acts of vandalism (shooting).

The main advantage of usage of glass insulators with RTV - coating is the improvement of an index of reliability, in particular, the reducing of in-service failure rate by the electric strength and mechanical strength.



## Laboratory

UMEK, JSC has got its own testing laboratory that was accredited by Rosaccreditatsia (accreditation certificate No. POC RU.0001.21AY47). This accreditation confirms the right of TL UMEK to perform tests in accordance with the Russian and international standards and complies with the criteria of Standard GOST ISO/IEC 17025-2009.

UMEK testing laboratory has got state-of-the-art equipment. Nowadays we use about 30 testing machines and more than 100 measuring devices that allow performing tests on many types of insulators: passing ceramic, rod and pin, suspension glass and porcelain, in addition to this, polymer rod and pin insulators. Testing equipment guarantees compliance with the national (GOST-R, industry standard (STO)), cross national (GOST) and international (IEC, ANSI) standards, among others, customer specifications.

Testing laboratory takes part in the round robin tests. The successful results of this confirm the quality of performed test in our laboratory, its competence and eligibility of the accreditation. TL UMEK provides routine testing at a customer's request and in presence of representatives of a customer.





We do our best to satisfy our customers! From the Arctic to the humid tropics, to the dry deserts, our glass insulators are suitable for any climate due to their high quality manufacturing. The UMEK brand has developed a reputation recognized by energy companies in Russia, Belarus, Kazakhstan, Azerbaijan, Georgia, Turkmenistan, and Kyrgyzstan. Our regular customers go beyond companies serving the power grid in these countries to include leading enterprises in the oil/gas and transportation sectors such as Gazprom, Rosneft, Surgutneftegaz, Lukoil, and Russian Railways.

Since 2012 we have been successfully reaching out to foreign markets. We have delivered to clients in Bulgaria, Serbia, Montenegro, Finland, Vietnam, and other countries.

It is our goal to satisfy customers with our products' high quality and with timely fulfillment of contract terms. We look forward to establishing long-term business relations with our clients.



**Contact us:**

**Address: Stroiteley St., 1B, Yuzhnouralsk,  
Chelyabinsk region, Russia**

**Tel.: (35134)4-05-33**

**e-mail: [sales@umek.pro](mailto:sales@umek.pro)**

**website: [www.umek.pro](http://www.umek.pro)**





## IEC standard







## Toughened Glass Suspension Insulator

## Ball and Socket

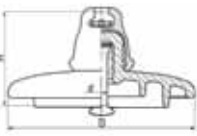
70 kN

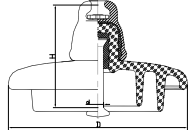
| Profile  | Standard  |   |   |
|--|---|---|---|
|  |  |  |  |
| Class IEC <sup>1</sup>                                   | U70BS   | U70BL   | U70BL   |
| Class GOST <sup>2</sup>                                  | PS70E   | PS70E   | PS70SS  |
| Minimum mechanical failing load, kN                      | 70  | 70  | 70  |
| Minimum mechanical residual strength, kN <sup>3</sup>    | 56  | 56  | 56  |
| Diameter of the insulating part (D), mm                  | 255   | 255   | 255   |
| Spacing, (H), mm   | 127   | 146   | 146   |
| Nominal creepage distance, mm                            | 320   | 320   | 415   |
| Ball and socket coupling (d), mm <sup>4</sup>            | 16  | 16  | 16  |
| Puncture voltage in insulating medium, kV <sup>5</sup>   | 130   | 130   | 130   |
| Dry lightning impulse withstand voltage, kV <sup>5</sup> |   |   |   |
| a. One unit, +/- , kV                                    | 100/100   | 100/100   | 110/110   |
| b. Short standard string (5 units), kV                   | 400/400   | 430/430   | 430/430   |
| Power frequency withstand voltage <sup>5</sup>           |   |   |   |
| Dry, kV  | 70  | 70  | 72  |
| Wet, kV  | 40  | 40  | 42  |
| Radio interference <sup>6</sup>                          | dB  | 60  | 60  |
|  | kV  | 20  | 20  |
|  | dB  | 86  | 86  |
|  | kV  | 25  | 30  |
| Zinc coating mass, not less than, g/m <sup>2</sup>       | 600   | 600   | 600   |
| Weight, kg   | 3.6   | 3.6   | 4,2   |

<sup>1</sup> in accordance with IEC 60305 standard

<sup>2</sup> in accordance with GOST 27661

<sup>3</sup> in accordance with IEC 60797 standard

<sup>4</sup> in accordance with IEC 60120 standard

<sup>5</sup> in accordance with IEC 60383-1 standard

<sup>6</sup> in accordance with IEC 60437 standard

All Insulators can be provided with a zinc sleeve and with RTV coating (see pages 6,7)



# Toughened Glass Suspension Insulator

# Ball and Socket

## 70 kN

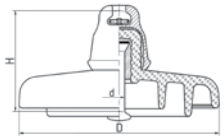
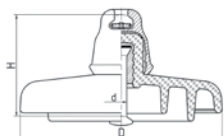
| Profile  | Fog type   |   |    |
|--|--|---|----|
|  |  |  |    |
| Class IEC <sup>1</sup>                                   | U70BSP   | U70BLP  |    |
| Class GOST <sup>2</sup>                                  | PSV70A   | PSV70A  |    |
| Minimum mechanical failing load, kN                      | 70   | 70  |    |
| Minimum mechanical residual strength, kN <sup>3</sup>    | 56   | 56  |    |
| Diameter of the insulating part (D), mm                  | 280  | 280   |    |
| Spacing, (H), mm   | 127  | 146   |    |
| Nominal creepage distance, mm                            | 445  | 445   |    |
| Ball and socket coupling (d), mm <sup>4</sup>            | 16   | 16  |    |
| Puncture voltage in insulating medium, kV <sup>5</sup>   | 130  | 130   |    |
| Dry lightning impulse withstand voltage, kV <sup>5</sup> |  |   |    |
| a. One unit, +/- , kV                                    | 125/125  | 125/125   |    |
| b. Short standard string (5 units), kV                   | 465/465  | 465/465   |    |
| Power frequency withstand voltage <sup>5</sup>           |  |   |    |
| Dry, kV  | 50   | 50  |    |
| Wet, kV  | 85   | 85  |    |
| Radio interference <sup>6</sup>                          | dB   | 60  | 60 |
|  | kV   | 20  | 20 |
|  | dB   | 86  | 86 |
|  | kV   | 30  | 30 |
| Zinc coating mass, not less than, g/m <sup>2</sup>       | 600  | 600   |    |
| Weight, kg   | 5.7  | 5.7   |    |

<sup>1</sup> in accordance with IEC 60305 standard

<sup>2</sup> in accordance with GOST 27661

<sup>3</sup> in accordance with IEC 60797 standard

<sup>4</sup> in accordance with IEC 60120 standard

<sup>5</sup> in accordance with IEC 60383-1 standard

<sup>6</sup> in accordance with IEC 60437 standard

All Insulators can be provided with a zinc sleeve and with RTV coating (see pages 6,7)

# Toughened Glass Suspension Insulator

# Ball and Socket

120 kN

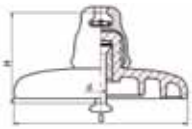
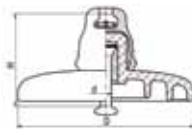
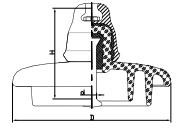
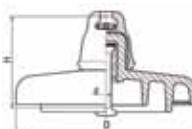
| Profile  | Standard  |  |   | Fog type  |
|--|---|--|---|---|
|  |  |  |  |  |
| Class IEC <sup>1</sup>                                   | U120B   | U120B  | U120B   | U120BP  |
| Class GOST <sup>2</sup>                                  | PS120B  | PS120B   | PS120SS   | PSV120B   |
| Minimum mechanical failing load, kN                      | 120   | 120  | 120   | 120   |
| Minimum mechanical residual strength, kN <sup>3</sup>    | 96  | 96   | 96  | 96  |
| Diameter of the insulating part (D), mm                  | 255   | 255  | 255   | 280   |
| Spacing, (H), mm   | 146   | 127  | 146   | 146   |
| Nominal creepage distance, mm                            | 330   | 330  | 415   | 445   |
| Ball and socket coupling (d), mm <sup>4</sup>            | 16  | 16   | 16  | 16  |
| Puncture voltage in insulating medium, kV <sup>5</sup>   | 130   | 130  | 130   | 130   |
| Dry lightning impulse withstand voltage, kV <sup>5</sup> |   |  |   |   |
| a. One unit, +/- , kV                                    | 100/100   | 100/100  | 110/110   | 125/125   |
| b. Short standard string (5 units), kV                   | 450/450   | 450/450  | 450/450   | 500/500   |
| Power frequency withstand voltage <sup>5</sup>           |   |  |   |   |
| Dry, kV  | 70  | 70   | 72  | 85  |
| Wet, kV  | 40  | 40   | 42  | 50  |
| Radio interference <sup>6</sup>                          | dB  | 60   | 60  | 60  |
|  | kV  | 20   | 20  | 20  |
|  | dB  | 86   | 86  | 86  |
|  | kV  | 30   | 30  | 30  |
| Zinc coating mass, not less than, g/m <sup>2</sup>       | 600   | 600  | 600   | 600   |
| Weight, kg   | 3.9   | 3.9  | 4,4   | 5.7   |

<sup>1</sup> in accordance with IEC 60305 standard

<sup>2</sup> in accordance with GOST 27661

<sup>3</sup> in accordance with IEC 60797 standard

<sup>4</sup> in accordance with IEC 60120 standard

<sup>5</sup> in accordance with IEC 60383-1 standard

<sup>6</sup> in accordance with IEC 60437 standard

All Insulators can be provided with a zinc sleeve and with RTV coating (see pages 6,7)

## Toughened Glass Suspension Insulator

## Ball and Socket

### 120 kN

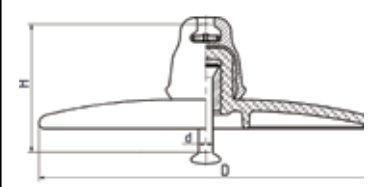
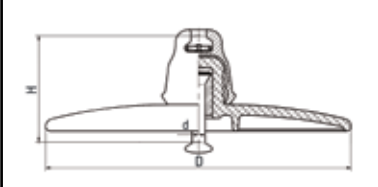
| Profile  | Open   |   |    |
|--|--|---|----|
|  |  |  |    |
| Class IEC <sup>1</sup>                                   | —  | —   |    |
| Class GOST <sup>2</sup>                                  | U120BA 112V  | U120BA 212V   |    |
| Minimum mechanical failing load, kN                      | 120  | 120   |    |
| Minimum mechanical residual strength, kN <sup>3</sup>    | 96   | 96  |    |
| Diameter of the insulating part (D), mm                  | 380  | 380   |    |
| Spacing, (H), mm   | 146  | 127   |    |
| Nominal creepage distance, mm                            | 365  | 365   |    |
| Ball and socket coupling (d), mm <sup>4</sup>            | 16   | 16  |    |
| Puncture voltage in insulating medium, kV <sup>5</sup>   | 130  | 130   |    |
| Dry lightning impulse withstand voltage, kV <sup>5</sup> |  |   |    |
| a. One unit, +/- , kV                                    | 95/95  | 95/95   |    |
| b. Short standard string (5 units), kV                   | 490/490  | 490/490   |    |
| Power frequency withstand voltage <sup>5</sup>           |  |   |    |
| Dry, kV  | 60   | 60  |    |
| Wet, kV  | 50   | 50  |    |
| Radio interference <sup>6</sup>                          | dB   | 60  | 60 |
|  | kV   | 20  | 20 |
|  | dB   | 86  | 86 |
|  | kV   | 30  | 30 |
| Zinc coating mass, not less than, g/m <sup>2</sup>       | 600  | 600   |    |
| Weight, kg   | 5,2  | 5,2   |    |

<sup>1</sup> in accordance with IEC 60305 standard

<sup>2</sup> in accordance with GOST 27661

<sup>3</sup> in accordance with IEC 60797 standard

<sup>4</sup> in accordance with IEC 60120 standard

<sup>5</sup> in accordance with IEC 60383-1 standard

<sup>6</sup> in accordance with IEC 60437 standard

All Insulators can be provided with a zinc sleeve and with RTV coating (see pages 6,7)



## Toughened Glass Suspension Insulator

## Ball and Socket

160 kN

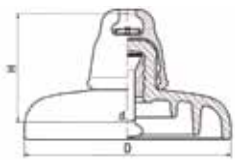
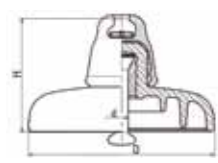
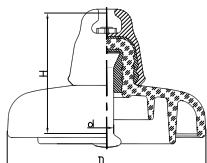
| Profile  | Standard  |  |   |
|--|---|--|---|
|  |  |  |  |
| Class IEC <sup>1</sup>                                   | U160BS  | U160BL   | U160BL  |
| Class GOST <sup>2</sup>                                  | PS160D  | PS160D   | PS160M  |
| Minimum mechanical failing load, kN                      | 160   | 160  | 160   |
| Minimum mechanical residual strength, kN <sup>3</sup>    | 128   | 128  | 128   |
| Diameter of the insulating part (D), mm                  | 280   | 280  | 280   |
| Spacing, (H), mm   | 146   | 170  | 170   |
| Nominal creepage distance, mm                            | 385   | 385  | 470   |
| Ball and socket coupling (d), mm <sup>4</sup>            | 20  | 20   | 20  |
| Puncture voltage in insulating medium, kV <sup>5</sup>   | 130   | 130  | 130   |
| Dry lightning impulse withstand voltage, kV <sup>5</sup> |   |  |   |
| a. One unit, +/- , kV                                    | 110/110   | 110/110  | 125/125   |
| b. Short standard string (5 units), kV                   | 510/510   | 540/540  | 540/540   |
| Power frequency withstand voltage <sup>5</sup>           |   |  |   |
| Dry, kV  | 75  | 75   | 80  |
| Wet, kV  | 45  | 45   | 45  |
| Radio interference <sup>6</sup>                          | dB  | 60   | 60  |
|  | kV  | 20   | 20  |
|  | dB  | 86   | 86  |
|  | kV  | 35   | 40  |
| Zinc coating mass, not less than, g/m <sup>2</sup>       | 600   | 600  | 600   |
| Weight, kg   | 6.2   | 6.2  | 6,8   |

<sup>1</sup> in accordance with IEC 60305 standard

<sup>2</sup> in accordance with GOST 27661

<sup>3</sup> in accordance with IEC 60797 standard

<sup>4</sup> in accordance with IEC 60120 standard

<sup>5</sup> in accordance with IEC 60383-1 standard

<sup>6</sup> in accordance with IEC 60437 standard

All Insulators can be provided with a zinc sleeve and with RTV coating (see pages 6,7)

# Toughened Glass Suspension Insulator

# Ball and Socket

## 160 kN

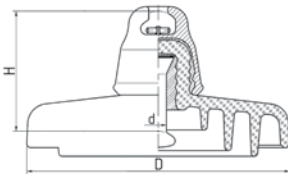
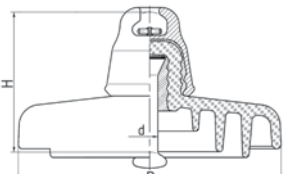
| Profile  | Fog type   |   |    |
|--|--|---|----|
|  |  |  |    |
| Class IEC <sup>1</sup>                                   | U160BSP  | U160BLP   |    |
| Class GOST <sup>2</sup>                                  | PSV160A  | PSV160A   |    |
| Minimum mechanical failing load, kN                      | 160  | 160   |    |
| Minimum mechanical residual strength, kN <sup>3</sup>    | 128  | 128   |    |
| Diameter of the insulating part (D), mm                  | 320  | 320   |    |
| Spacing, (H), mm   | 146  | 170   |    |
| Nominal creepage distance, mm                            | 545  | 545   |    |
| Ball and socket coupling (d), mm <sup>4</sup>            | 20   | 20  |    |
| Puncture voltage in insulating medium, kV <sup>5</sup>   | 130  | 130   |    |
| Dry lightning impulse withstand voltage, kV <sup>5</sup> |  |   |    |
| a. One unit, +/- , kV                                    | 140/140  | 140/140   |    |
| b. Short standard string (5 units), kV                   | 525/525  | 560/560   |    |
| Power frequency withstand voltage <sup>5</sup>           |  |   |    |
| Dry, kV  | 90   | 90  |    |
| Wet, kV  | 55   | 55  |    |
| Radio interference <sup>6</sup>                          | dB   | 60  | 60 |
|  | kV   | 20  | 20 |
|  | dB   | 86  | 86 |
|  | kV   | 35  | 35 |
| Zinc coating mass, not less than, g/m <sup>2</sup>       | 600  | 600   |    |
| Weight, kg   | 8.0  | 8.0   |    |

<sup>1</sup> in accordance with IEC 60305 standard

<sup>2</sup> in accordance with GOST 27661

<sup>3</sup> in accordance with IEC 60797 standard

<sup>4</sup> in accordance with IEC 60120 standard

<sup>5</sup> in accordance with IEC 60383-1 standard

<sup>6</sup> in accordance with IEC 60437 standard

All Insulators can be provided with a zinc sleeve and with RTV coating (see pages 6,7)

# Toughened Glass Suspension Insulator

# Ball and Socket

210 kN

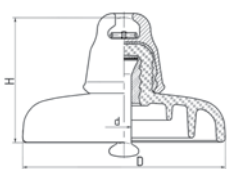
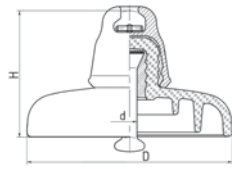
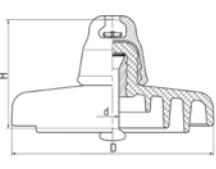
| Profile  | Standard  |  | Fog type  |
|--|---|--|---|
|  |  |  |  |
| Class IEC <sup>1</sup>                                   | U210B   | U210B  | U210BP  |
| Class GOST <sup>2</sup>                                  | PS210V  | PS210M   | PSV210D   |
| Minimum mechanical failing load, kN                      | 210   | 210  | 210   |
| Minimum mechanical residual strength, kN <sup>3</sup>    | 168   | 168  | 168   |
| Diameter of the insulating part (D), mm                  | 280   | 280  | 320   |
| Spacing, (H), mm   | 170   | 195  | 170   |
| Nominal creepage distance, mm                            | 380   | 490  | 555   |
| Ball and socket coupling (d), mm <sup>4</sup>            | 20  | 20   | 20  |
| Puncture voltage in insulating medium, kV <sup>5</sup>   | 130   | 130  | 130   |
| Dry lightning impulse withstand voltage, kV <sup>5</sup> |   |  |   |
| a. One unit, +/- , kV                                    | 110/110   | 125/125  | 140/140   |
| b. Short standard string (5 units), kV                   | 545/545   | 545/545  | 550/550   |
| Power frequency withstand voltage <sup>5</sup>           |   |  |   |
| Dry, kV  | 72  | 80   | 90  |
| Wet, kV  | 45  | 45   | 55  |
| Radio interference <sup>6</sup>                          | dB  | 60   | 60  |
|  | kV  | 20   | 20  |
|  | dB  | 86   | 86  |
|  | kV  | 40   | 40  |
| Zinc coating mass, not less than, g/m <sup>2</sup>       | 600   | 600  | 600   |
| Weight, kg   | 7.2   | 8,2  | 8.5   |

<sup>1</sup> in accordance with IEC 60305 standard

<sup>2</sup> in accordance with GOST 27661

<sup>3</sup> in accordance with IEC 60797 standard

<sup>4</sup> in accordance with IEC 60120 standard

<sup>5</sup> in accordance with IEC 60383-1 standard

<sup>6</sup> in accordance with IEC 60437 standard

All Insulators can be provided with a zinc sleeve and with RTV coating (see pages 6,7)



## Toughened Glass Suspension Insulator

## Ball and Socket

### 240 kN, 300 kN

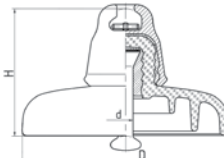
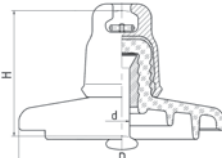
| Profile  | Standard   |   |    |
|--|--|---|----|
|  |  |  |    |
| Class IEC <sup>1</sup>                                   | —  | U300B   |    |
| Class GOST <sup>2</sup>                                  | PS240V   | PS300V  |    |
| Minimum mechanical failing load, kN                      | 240  | 300   |    |
| Minimum mechanical residual strength, kN <sup>3</sup>    | 192  | 240   |    |
| Diameter of the insulating part (D), mm                  | 290  | 320   |    |
| Spacing, (H), mm   | 170  | 195   |    |
| Nominal creepage distance, mm                            | 380  | 390   |    |
| Ball and socket coupling (d), mm <sup>4</sup>            | 24   | 24  |    |
| Puncture voltage in insulating medium, kV <sup>5</sup>   | 130  | 130   |    |
| Dry lightning impulse withstand voltage, kV <sup>5</sup> |  |   |    |
| a. One unit, +/- , kV                                    | 110/110  | 130/130   |    |
| b. Short standard string (5 units), kV                   | 545/545  | 530/530   |    |
| Power frequency withstand voltage <sup>5</sup>           |  |   |    |
| Dry, kV  | 72   | 82  |    |
| Wet, kV  | 45   | 50  |    |
| Radio interference <sup>6</sup>                          | dB   | 60  | 60 |
|  | kV   | 20  | 20 |
|  | dB   | 86  | 86 |
|  | kV   | 40  | 40 |
| Zinc coating mass, not less than, g/m <sup>2</sup>       | 600  | 600   |    |
| Weight, kg   | 7,1  | 10  |    |

<sup>1</sup> in accordance with IEC 60305 standard

<sup>2</sup> in accordance with GOST 27661

<sup>3</sup> in accordance with IEC 60797 standard

<sup>4</sup> in accordance with IEC 60120 standard

<sup>5</sup> in accordance with IEC 60383-1 standard

<sup>6</sup> in accordance with IEC 60437 standard

All Insulators can be provided with a zinc sleeve and with RTV coating (see pages 6,7)

# ANSI standard



## Toughened Glass Suspension Insulator

## Ball and Socket

70 kN / 120 kN / 160 kN

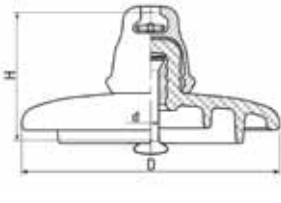
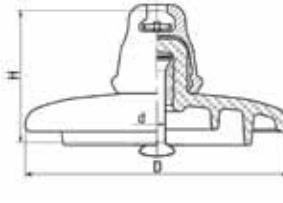
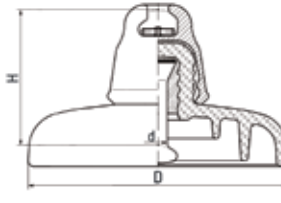
| Profile   |  |  |  |
|---|---|--|---|
| Class ANSI <sup>1</sup>                               | 52-3/52-3-H   | 52-5/52-5-H  | 52-8/52-8-H   |
| Spacing (H) inch (mm)                                 | 5 ¾ (146)   | 5 ¾ (146)  | 5 ¾ (146)   |
| Diameter (D) inch (mm)                                | 10 (255)  | 10 (255)   | 11 (280)  |
| Connecting hardware coupling <sup>2</sup>             | B&S type B  | B&S type J   | B&S type K  |
| Leakage distance inch (mm)                            | 12 5/8 (320)  | 13 (330)   | 15 1/8 (385)  |
| Combined mechanical & electrical strength, lb (kN)    | 15700 (70)/20000 (89)   | 26900(120)/30000(133)  | 36000(160)/48000 (178)  |
| Mechanical impact strength, lb x inch (N·m)           | 400(45)   | 400(45)  | 400(45)   |
| Residual strength, lb (kN)                            | 9400(42)  | 16100(72)  | 21580(96)   |
| Tension proof, lb (kN)                                | 7800(35)  | 13400(60)  | 17980(80)   |
| Low-frequency dry flashover, kV <sup>2</sup>          | 80  | 80   | 80  |
| Low-frequency wet flashover, kV <sup>2</sup>          | 50  | 50   | 50  |
| Critical impulse flashover, positive, kV <sup>2</sup> | 125   | 125  | 125   |
| Critical impulse flashover, negative, kV <sup>2</sup> | 130   | 130  | 130   |
| Puncture voltage, kV <sup>2</sup>                     | 130   | 130  | 130   |
| R.I.V. test voltage, rms to ground, kV <sup>2</sup>   | 10  | 10   | 10  |
| Maximum RIV at 1000 kHz, μV                           | 50  | 50   | 50  |
| Weight, lb (kg)                                       | 8,82 (4,0)  | 8,82 (4,0)   | 13,6 (6,2)  |

<sup>1</sup> in accordance with ANSI C.29.2.B standard

<sup>2</sup> in accordance with ANSI C 29.1 standard

All Insulators can be provided with a zinc sleeve and with RTV coating (see pages 6,7)

# GOST standard





# Toughened Glass Suspension Insulator

# Ball and Socket

## 70 kN

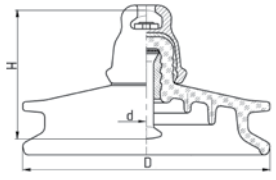
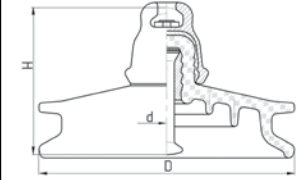
|   |    |  |   |
|---|----|--|---|
| Profile   |    |  |  |
| Class GOST <sup>1</sup>                                 |    | PSD70E   | PSD70E  |
| Minimum mechanical failing load, kN                     |    | 70   | 70  |
| Minimum mechanical residual strength, kN                |    | 56   | 56  |
| Diameter of the insulating part (D), mm                 |    | 270  | 270   |
| Spacing (H), mm   |    | 127  | 146   |
| Nominal creepage distance, mm                           |    | 411  | 411   |
| Ball and socket coupling, d (IEC 60120), mm             |    | 16   | 16  |
| Puncture voltage in insulating medium, kV               |    | 130  | 130   |
| 50 Hz withstand voltage (dry), kV                       |    | 75   | 75  |
| 50 Hz withstand voltage (wet), kV                       |    | 45   | 45  |
| Dry lightning impulse withstand voltage, 1.2/50 +/-, kV |    | 110/110  | 110/110   |
| Radio interference                                      | dB | 60   | 60  |
|   | kV | 20   | 20  |
|   | dB | 86   | 86  |
|   | kV | 25   | 25  |
| Weight, kg  |    | 4.6  | 4.6   |

<sup>1</sup>in accordance with GOST 27661

All Insulators can be provided with a zinc sleeve and with RTV coating (see pages 6,7)

## Toughened Glass Suspension Insulator

## Ball and Socket

100 kN

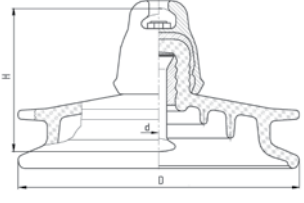
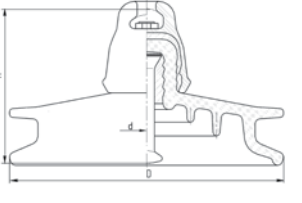
|   |  |   |    |
|---|--|---|----|
| Profile   |  |  |    |
| Class GOST <sup>1</sup>                                 | PSD100V  | PSD100V   |    |
| Minimum mechanical failing load, kN                     | 100  | 100   |    |
| Minimum mechanical residual strength, kN                | 80   | 80  |    |
| Diameter of the insulating part (D), mm                 | 280  | 280   |    |
| Spacing (H), mm   | 127  | 146   |    |
| Nominal creepage distance, mm                           | 425  | 425   |    |
| Ball and socket coupling, d (IEC 60120), mm             | 16   | 16  |    |
| Puncture voltage in insulating medium, kV               | 130  | 130   |    |
| 50 Hz withstand voltage (dry), kV                       | 75   | 75  |    |
| 50 Hz withstand voltage (wet), kV                       | 45   | 45  |    |
| Dry lightning impulse withstand voltage, 1.2/50 +/-, kV | 100/100  | 100/100   |    |
| Radio interference                                      | dB   | 60  | 60 |
|   | kV   | 20  | 20 |
|   | dB   | 86  | 86 |
|   | kV   | 25  | 25 |
| Weight, kg  | 5.1  | 5.1   |    |

<sup>1</sup>in accordance with GOST 27661

## Toughened glass pin insulator ShS 10 ED

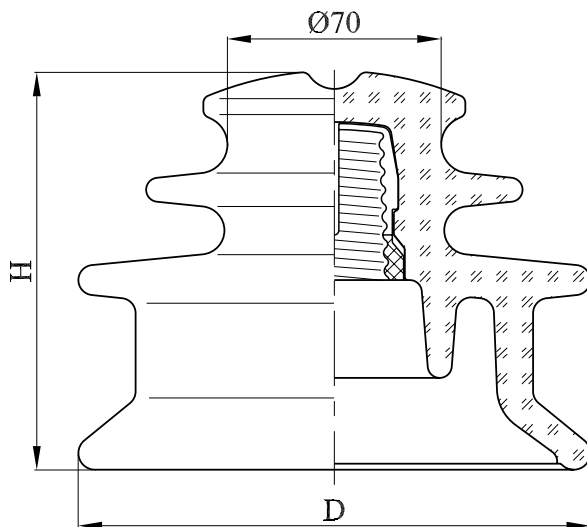

| Class GOST <sup>1</sup>                            | ShS 10 ED |
|--|-----------|
| Nominal voltage, kV                                | 10        |
| Maximum working voltage, kV                        | 12        |
| Mechanical failing load (on bending), kN           | 12,5      |
| Diameter, D, mm                                    | 170       |
| Spacing, H, mm                                     | 132       |
| Creepage distance, mm                              | 340       |
| Puncture withstand voltage (in oil), kV            | 130       |
| Radio interference voltage, 34 dB, kV              | 7         |
| Dry lightning impulse withstand voltage 1,2/50, kV | 100       |
| Weight, kg   | 2,2       |

<sup>1</sup>in accordance with GOST 1232-82

## Toughened glass pin insulator ShS 20 ED

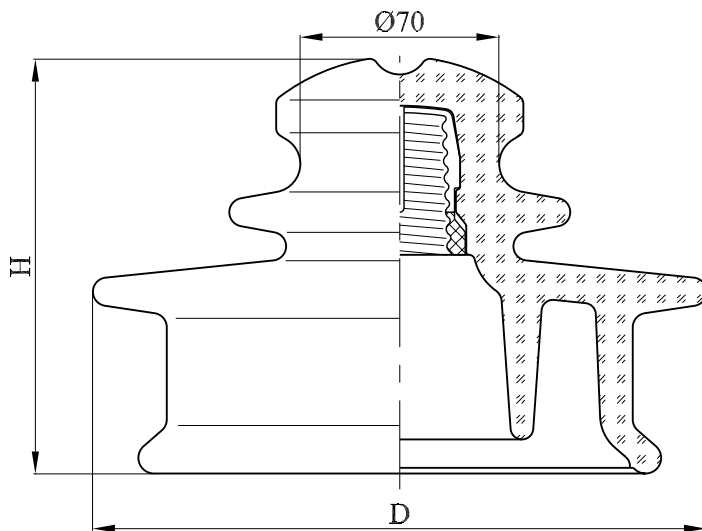

| Class GOST <sup>1</sup>                            | ShS 20 ED |
|--|-----------|
| Nominal voltage, kV                                | 20        |
| Maximum working voltage, kV                        | 24        |
| Mechanical failing load (on bending), kN           | 13,0      |
| Diameter, D, mm                                    | 216       |
| Spacing, H, mm                                     | 146       |
| Creepage distance, mm                              | 420       |
| Puncture withstand voltage (in oil), kV            | 140       |
| Radio interference voltage, 34 dB, kV              | 13        |
| Dry lightning impulse withstand voltage 1,2/50, kV | 125       |
| Weight, kg   | 3,07      |

<sup>1</sup>in accordance with GOST 1232-82



## Manufacturing process

A batch mixture for glass melting consists of 7 components. All raw materials that we order, pass the incoming control, perform chemical analysis against a set of rules. Dosing and mixture of materials are made in accordance with the strict receipt. A charge-makeup area is fitted with modern automatic equipment.

A glass melting process runs in the glass furnace which overall total is 200 tons at a temperature of 1500°C. The glass furnace's output is about 35 tons per 24 hours. The level of glass mass, feed of a batch mixture to a glass furnace, temperature control are automatically regulated from a workplace.

Glass mass goes through the channel and then it is fed to a feeder, where it takes drop-shape form and supplies for the molding. The automatic 12-positional German molding machine manufactures up to 12,500 glass details per day. The product yield is 80 % or more in equivalent of U70B, which is more than 10,000 glass parts per day.

The automatic line for glass production consists of a balancing furnace, toughening machine and line of double thermal shock. 100% of glass details are subjects of positive and negative thermal shock. All glass details with inherent defects are sorted during the process of double thermal shock. Moreover, every glass detail is visually checked by a controller to identify visible defects.

The assembling of insulators is performed on the 24-position armoring conveyer with the manual and computer control. The average production capacity is 3,5 million units. The assembled insulator goes through the cycle of thermal wet treatment, after that glass insulators go through complete (100%) control by 50% tensional mechanical force, then they are completed with a locking device, marked and collected in a string, then packaged.

Inspection and control are performed at all stages of production. Raw materials, furniture, fittings, packages are subjects of the incoming control.

The chosen control points, during the production of insulating details and during the assembling of insulators, prevent passing nonconforming components to the next manufacturing stage. Insulators, before packaging, are subjects to the complete inspection and sample tests. The sampling of insulators from each batch comes to the testing laboratory for testing in accordance with the required international and national standards: IEC, ANSI, GOST.

Then insulators are packaged and film-wrapped for the protection from contamination during transportation.









## Packaging and Delivery

The plant provides freight shipping by land and by sea.

The land carriage is performed by trucks. There are 2 kinds of package – package on pallette and package with crates for land carriages. Such kinds of package ensure safe delivery of different types of insulators. 20 tons of goods may be load in a truck.

We use 20" and 40" containers for sea transportation. There is a special kind of package for sea transportation – sea package, as well as a package with crates. The maximum weight of insulators for 1 container is up to 26 tons.

We use boards of soft wood for producing packages.

Dimensions of the package and the quantity of insulators on one pallette are stipulated in the loading norms on page 30. The quantity of insulators on one pallette may be changed depending on the total amount of the ordered insulators as well as a type of transport and a customer wishes.

Our package guarantees reliable protection of insulators from the loading to the final destination with 6 transshipments.





---

Crate (photo 1)



---

Sea package (photo 2)



---

Package with crates (photo 3)



---

Package on pallet (photo 4)



| Types of Insulators (GOST)      | Types of Insulators (IEC) | Types of package     | Quantity of insulators per package, pcs. | Dimensions, mm      | Netto weight/ package, kg | Gross weight/ package, kg. | Weight of insulator, kg |
|---------------------------------|---------------------------|----------------------|--|---------------------|---------------------------|----------------------------|-------------------------|
| PS70E<br>(H=127 mm)             | U70BS                     | Package with crates  | 96                                       | 1105x905x1285       | 345,6                     | 477,4                      | 3,6                     |
|                                 |                           |                      | 72                                       | 1105x905x1000       | 259,2                     | 391                        |                         |
|                                 |                           | Package              | 200                                      | 1150x750x1800       | 720                       | 741                        |                         |
|                                 |                           |                      | 175                                      | 1150x750x1600       | 630                       | 681,5                      |                         |
|                                 |                           |                      | 125                                      | 1150x750x1200       | 450                       | 469                        |                         |
|                                 |                           |                      | 100                                      | 1150x750x1000       | 360                       | 378                        |                         |
|                                 |                           | Sea package          | 200                                      | 1150x720x1800       | 720                       | 741                        |                         |
|                                 |                           |                      | 125                                      | 1150x720x1200       | 450                       | 469                        |                         |
|                                 |                           |                      | 100                                      | 1150x720x1000       | 360                       | 406                        |                         |
|                                 |                           | PS70E<br>(H=146 mm)  | U70BL                                    | Package with crates | 96                        | 1105x1005x1285             |                         |
| 72                              | 1105x1005x1000            |                      |  |                     | 259,2                     | 403                        |                         |
| Package                         | 200                       |                      |  | 1150x800x1800       | 720                       | 800                        |                         |
|                                 | 175                       |                      |  | 1150x800x1600       | 630                       | 704                        |                         |
|                                 | 125                       |                      |  | 1150x800x1200       | 450                       | 512                        |                         |
|                                 | 100                       |                      |  | 1150x800x1000       | 360                       | 416                        |                         |
| Sea package                     | 200                       |                      |  | 1150x800x1800       | 720                       | 788                        |                         |
|                                 | 125                       |                      |  | 1150x800x1200       | 450                       | 503                        |                         |
|                                 | 100                       |                      |  | 1150x800x1000       | 360                       | 408                        |                         |
| PS70SS<br>(H=146 mm)            | U70BL                     |                      |  | Package             | 200                       | 1155x840x1870              | 840                     |
|                                 |                           | 175                  | 1155x840x1665                            |                     | 735                       | 812                        |                         |
|                                 |                           | 125                  | 1155x840x1255                            |                     | 525                       | 589                        |                         |
|                                 |                           | 100                  | 1155x840x1050                            |                     | 420                       | 478                        |                         |
| PS120B<br>(H=127 mm)            | ---                       | Package with crates  | 96                                       | 1105x905x1285       | 384                       | 512,6                      | 4,0                     |
|                                 |                           |                      | 72                                       | 1105x905x1000       | 288                       | 416,6                      |                         |
|                                 |                           | Package              | 200                                      | 1150x750x1800       | 800                       | 861,5                      |                         |
|                                 |                           |                      | 175                                      | 1150x750x1600       | 700                       | 730,2                      |                         |
|                                 |                           |                      | 125                                      | 1150x750x1200       | 500                       | 545,1                      |                         |
|                                 |                           |                      | 100                                      | 1150x750x1000       | 400                       | 439,2                      |                         |
|                                 |                           | Sea package          | 200                                      | 1150x720x1800       | 800                       | 869,7                      |                         |
|                                 |                           |                      | 125                                      | 1150x720x1200       | 500                       | 554,4                      |                         |
|                                 |                           |                      | 100                                      | 1150x720x1000       | 400                       | 449,2                      |                         |
|                                 |                           | PS120B<br>(H=146 mm) | U120B                                    | Package with crates | 96                        | 1105x1005x1285             |                         |
| 72                              | 1105x1005x1000            |                      |  |                     | 288                       | 428,1                      |                         |
| Package                         | 200                       |                      |  | 1150x800x1800       | 800                       | 876,9                      |                         |
|                                 | 175                       |                      |  | 1150x800x1600       | 700                       | 772,0                      |                         |
|                                 | 125                       |                      |  | 1150x800x1200       | 500                       | 560,3                      |                         |
|                                 | 100                       |                      |  | 1150x800x1000       | 400                       | 455,0                      |                         |
| Sea package                     | 200                       |                      |  | 1155x805x1800       | 800                       | 871,9                      |                         |
|                                 | 125                       |                      |  | 1155x805x1200       | 500                       | 556,1                      |                         |
|                                 | 100                       |                      |  | 1155x805x1000       | 400                       | 450,8                      |                         |
| PS120B<br>PS120SS<br>(H=146 mm) | U120B                     |                      |  | Package             | 200                       | 1155x840x1870              | 880                     |
|                                 |                           | 175                  | 1155x840x1665                            |                     | 770                       | 847                        |                         |
|                                 |                           | 125                  | 1155x840x1255                            |                     | 550                       | 614                        |                         |
|                                 |                           | 100                  | 1155x840x1050                            |                     | 440                       | 498                        |                         |

# Container / Truck Load

| Truck                     |                             |            | 20 foot container         |                             |            | 40 foot container         |                             |            |
|---------------------------|-----------------------------|------------|---------------------------|-----------------------------|------------|---------------------------|-----------------------------|------------|
| Quantity of packages, pcs | Quantity of insulators, pcs | Weight, kg | Quantity of packages, pcs | Quantity of insulators, pcs | Weight, kg | Quantity of packages, pcs | Quantity of insulators, pcs | Weight, kg |
| 28                        | 3840                        | 19623      | 12                        | 2016                        | 9620       | 26                        | 4368                        | 20680      |
| 16                        |                             |            | 12                        |                             |            | 26                        |                             |            |
| 30                        | 5250                        | 20445      |                           |                             |            |                           |                             |            |
|                           |                             |            |                           |                             |            |                           |                             |            |
|                           |                             |            | 32                        | 3200                        | 12698      | 64                        | 6400                        | 25984      |
| 26                        | 3576                        | 19669      | 10                        | 1680                        | 8280       | 22                        | 3696                        | 17550      |
| 15                        |                             |            | 10                        |                             |            | 22                        |                             |            |
| 28                        | 4900                        | 19706      |                           |                             |            |                           |                             |            |
|                           |                             |            |                           |                             |            |                           |                             |            |
|                           |                             |            | 14                        | 2800                        | 10388      | 28                        | 5600                        | 20776      |
|                           |                             |            | 14                        | 3150                        | 12080      | 28                        | 6300                        | 24130      |
|                           |                             |            | 14                        |                             |            | 28                        |                             |            |
| 25                        | 4375                        | 20300      |                           |                             |            |                           |                             |            |
|                           |                             |            | 12                        | 1500                        | 12504      |                           |                             |            |
|                           |                             |            | 12                        | 1200                        |            | 56                        | 5600                        | 26096      |
| 28                        | 3552                        | 19835      | 12                        | 2016                        | 10210      | 26                        | 4368                        | 22000      |
| 12                        |                             |            | 12                        |                             |            | 26                        |                             |            |
| 26                        | 4550                        | 19461      |                           |                             |            |                           |                             |            |
|                           |                             |            |                           |                             |            |                           |                             |            |
|                           |                             |            | 14                        | 3150                        | 13643      |                           |                             |            |
|                           |                             |            | 14                        |                             |            | 60                        | 6000                        | 26160      |
| 26                        | 3288                        | 19686      | 10                        | 1680                        | 8790       | 22                        | 3696                        | 18630      |
| 11                        |                             |            | 10                        |                             |            | 22                        |                             |            |
| 25                        | 4375                        | 19782,5    | 14                        | 2800                        | 11650      | 28                        | 5600                        | 23296      |
|                           |                             |            | 14                        | 3150                        | 13520      | 28                        | 5900                        | 25660      |
|                           |                             |            | 14                        |                             |            | 24                        |                             |            |
|                           |                             |            | 14                        | 3150                        | 13706      | 28                        | 5900                        | 25660      |
|                           |                             |            | 14                        |                             |            | 24                        |                             |            |
| 24                        | 4200                        | 20328      |                           |                             |            |                           |                             |            |
|                           |                             |            |                           |                             |            |                           |                             |            |

| Types of Insulators (GOST)      | Types of Insulators (IEC) | Types of package                | Quantity of insulators per package, pcs. | Dimensions, mm      | Netto weight/ package, kg | Gross weight/ package, kg. | Weight of insulator, kg |       |       |     |
|---------------------------------|---------------------------|---------------------------------|--|---------------------|---------------------------|----------------------------|-------------------------|-------|-------|-----|
| PSD70E<br>(H=127 mm)            | ---                       | Package with crates             | 96                                       | 1155x905x1310       | 441,6                     | 582                        | 4,6                     |       |       |     |
|                                 |                           |                                 | 72                                       | 1155x905x1015       | 331,2                     | 446                        |                         |       |       |     |
|                                 |                           | Package                         | 120                                      | 1150x740x1850       | 552                       | 620                        |                         |       |       |     |
|                                 |                           |                                 | 100                                      | 1150x740x1575       | 460                       | 532                        |                         |       |       |     |
|                                 |                           |                                 | 80                                       | 1150x740x1285       | 368                       | 422                        |                         |       |       |     |
|                                 |                           |                                 | 60                                       | 1150x740x990        | 276                       | 323                        |                         |       |       |     |
|                                 |                           | Sea package                     | 120                                      | 1150x720x1850       | 552                       | 620                        |                         |       |       |     |
|                                 |                           |                                 | 80                                       | 1155x725x1300       | 368                       | 433                        |                         |       |       |     |
|                                 |                           |                                 | 60                                       | 1155x725x1015       | 276                       | 330                        |                         |       |       |     |
|                                 |                           | PSD70E<br>(H=146 mm)            | ---                                      | Package with crates | 96                        | 1155x1005x1310             |                         | 441,6 | 595,3 | 4,6 |
|                                 |                           |                                 |  |                     | 72                        | 1155x1005x1015             |                         | 331,2 | 456   |     |
|                                 |                           |                                 |  | Package             | 120                       | 1150x810x1850              |                         | 552   | 662   |     |
| 100                             | 1150x810x1575             |                                 |  |                     | 460                       | 557                        |                         |       |       |     |
| 80                              | 1150x810x1285             |                                 |  |                     | 368                       | 452                        |                         |       |       |     |
| 60                              | 1150x810x990              |                                 |  |                     | 276                       | 347                        |                         |       |       |     |
| Sea package                     | 120                       |                                 |  | 1150x810x1850       | 552                       | 662                        |                         |       |       |     |
|                                 | 80                        |                                 |  | 1150x810x1285       | 368                       | 446                        |                         |       |       |     |
|                                 | 60                        |                                 |  | 1150x810x990        | 276                       | 340                        |                         |       |       |     |
| PSV70A<br>PSV120B<br>(H=127 mm) | ---                       |                                 |  | Package with crates | 96                        | 1255x905x1423              | 547,2                   | 660,7 | 5,7   |     |
|                                 |                           |                                 |  |                     | 72                        | 1255x905x1111              | 410,4                   | 530,5 |       |     |
|                                 |                           |                                 |  | Package             | 120                       | 1170x700x1734              | 684                     | 727   |       |     |
|                                 |                           | 100                             | 1170x700x1475                            |                     | 570                       | 610                        |                         |       |       |     |
|                                 |                           | 80                              | 1170x700x1216                            |                     | 456                       | 494                        |                         |       |       |     |
|                                 |                           | 60                              | 1170x700x957                             |                     | 342                       | 380                        |                         |       |       |     |
|                                 |                           | Sea package                     | 100                                      | 1175x705x1480       | 570                       | 626                        |                         |       |       |     |
|                                 |                           |                                 | 80                                       | 1175x705x1235       | 456                       | 506                        |                         |       |       |     |
|                                 |                           |                                 | 60                                       | 1175x705x990        | 342                       | 390                        |                         |       |       |     |
|                                 |                           | PSV70A<br>PSV120B<br>(H=146 mm) | U120BP                                   | Package with crates | 96                        | 1255x1005x1423             | 547,2                   | 670,5 |       | 5,7 |
|                                 |                           |                                 |  |                     | 72                        | 1255x1005x1111             | 410,4                   | 542,3 |       |     |
|                                 |                           |                                 |  | Package             | 100                       | 1165x705x1430              | 570                     | 633,9 |       |     |
| 80                              | 1165x705x1190             |                                 |  |                     | 456                       | 508                        |                         |       |       |     |
| 60                              | 1165x705x905              |                                 |  |                     | 342                       | 384                        |                         |       |       |     |
| 100                             | 1175x705x1480             |                                 |  |                     | 570                       | 631                        |                         |       |       |     |
| Sea package                     | 80                        |                                 |  | 1175x705x1235       | 456                       | 510                        |                         |       |       |     |
|                                 | 60                        |                                 |  | 1175x705x990        | 342                       | 390                        |                         |       |       |     |
|                                 | PS160D<br>(H=146 mm)      |                                 |  | U160BS              | Package with crates       | 96                         | 1205x1005x1380          | 595,2 | 751,2 |     |
| 72                              |                           |                                 |  |                     |                           | 1205x1005x1075             | 446,4                   | 546   |       |     |
| Package                         |                           |                                 |  |                     | 100                       | 1155x705x1460              | 620                     | 677   |       |     |
|                                 |                           |                                 |  |                     | 80                        | 1155x705x1210              | 496                     | 532   |       |     |
|                                 |                           | 60                              | 1155x705x960                             |                     | 372                       | 418                        |                         |       |       |     |
| Sea package                     |                           | 100                             | 1155x705x1430                            |                     | 620                       | 671                        |                         |       |       |     |
|                                 |                           | 80                              | 1155x705x1210                            |                     | 496                       | 550,5                      |                         |       |       |     |
|                                 |                           | 60                              | 1155x705x960                             |                     | 372                       | 420,2                      |                         |       |       |     |
| PS160D<br>(H=170 mm)            |                           | U160BL                          | Package with crates                      |                     | 96                        | 1205x1155x1380             | 595,2                   | 726,6 | 6,2   |     |
|                                 |                           |                                 |  |                     | 72                        | 1205x1155x1075             | 446,4                   | 586   |       |     |
|                                 |                           |                                 | Package                                  |                     | 100                       | 1155x775x1460              | 620                     | 679   |       |     |
|                                 |                           |                                 |  |                     | 80                        | 1155x775x1210              | 496                     | 551   |       |     |
|                                 | 60                        |                                 |  | 1155x775x960        | 372                       | 421                        |                         |       |       |     |
|                                 | Sea package               |                                 | 100                                      | 1155x775x1460       | 620                       | 683                        |                         |       |       |     |
|                                 |                           |                                 | 80                                       | 1155x775x1210       | 496                       | 552                        |                         |       |       |     |
|                                 |                           |                                 | 60                                       | 1155x775x960        | 372                       | 421                        |                         |       |       |     |

| Truck                     |                             |            | 20 foot container         |                             |            | 40 foot container         |                             |            |
|---------------------------|-----------------------------|------------|---------------------------|-----------------------------|------------|---------------------------|-----------------------------|------------|
| Quantity of packages, pcs | Quantity of insulators, pcs | Weight, kg | Quantity of packages, pcs | Quantity of insulators, pcs | Weight, kg | Quantity of packages, pcs | Quantity of insulators, pcs | Weight, kg |
| 28                        | 3264                        | 19864      | 12                        | 2016                        | 11600      | 26                        | 4368                        | 25300      |
| 8                         |                             |            | 12                        |                             |            | 26                        |                             |            |
| 32                        | 3840                        | 19840      |                           |                             |            |                           |                             |            |
|                           |                             |            |                           |                             |            |                           |                             |            |
|                           |                             |            | 14                        | 1960                        | 10628      | 32                        | 4480                        | 24416      |
|                           |                             |            | 14                        |                             |            | 32                        |                             |            |
| 25                        | 3192                        | 19898      | 10                        | 1680                        | 9660       | 22                        | 3696                        | 21230      |
| 11                        |                             |            | 10                        |                             |            | 22                        |                             |            |
| 30                        | 3600                        | 19860      |                           |                             |            |                           |                             |            |
|                           |                             |            |                           |                             |            |                           |                             |            |
|                           |                             |            | 14                        | 1960                        | 11004      | 28                        | 3920                        | 22008      |
|                           |                             |            | 14                        |                             |            | 28                        |                             |            |
| 37                        | 2664                        | 19629      | 20                        | 1440                        | 10060      | 44                        | 3168                        | 22132      |
| 33                        | 3300                        | 20130      |                           |                             |            |                           |                             |            |
|                           |                             |            |                           |                             |            |                           |                             |            |
|                           |                             |            | 13                        | 1820                        | 11648      | 30                        | 4080                        | 26100      |
|                           |                             |            | 13                        |                             |            | 28                        |                             |            |
| 36                        | 2592                        | 19523      | 18                        | 1296                        | 9198       | 40                        | 2880                        | 20440      |
| 31                        | 3100                        | 19651      |                           |                             |            |                           |                             |            |
|                           |                             |            |                           |                             |            |                           |                             |            |
|                           |                             |            | 13                        | 1820                        | 11700      | 30                        | 4080                        | 26220      |
|                           |                             |            | 13                        |                             |            | 28                        |                             |            |
| 26                        | 2496                        | 19531      | 20                        | 1440                        | 10900      | 40                        | 2880                        | 21840      |
| 30                        | 3000                        | 20310      |                           |                             |            |                           |                             |            |
|                           |                             |            |                           |                             |            |                           |                             |            |
|                           |                             |            | 16                        | 2240                        | 15531      | 62                        | 3720                        | 26052      |
|                           |                             |            | 16                        |                             |            |                           |                             |            |
| 34                        | 2448                        | 19925      | 16                        | 1152                        | 8860       | 36                        | 2592                        | 19900      |
| 29                        | 2900                        | 19691      |                           |                             |            |                           |                             |            |
|                           |                             |            |                           |                             |            |                           |                             |            |
|                           |                             |            | 14                        | 1960                        | 13622      | 60                        | 3600                        | 25260      |
|                           |                             |            | 14                        |                             |            |                           |                             |            |





| Types of Insulators (GOST)     | Types of Insulators (IEC) | Types of package    | Quantity of insulators per package, pcs. | Dimensions, mm | Netto weight/ package, kg | Gross weight/ package, kg. | Weight of insulator, kg |       |
|--------------------------------|---------------------------|---------------------|--|----------------|---------------------------|----------------------------|-------------------------|-------|
| PS160K<br>PS160M<br>(H=170 mm) | U160BL                    | Package             | 100                                      | 1155x795x1470  | 680                       | 727,5                      | 6,8                     |       |
|                                |                           |                     | 80                                       | 1155x795x1220  | 544                       | 687,6                      |                         |       |
| PSV160A<br>(H=146 mm)          | U160BSP                   | Package with crates | 54                                       | 1025x1005x1220 | 432                       | 537,3                      | 8,0                     |       |
|                                |                           |                     | 36                                       | 1025x1005x865  | 288                       | 366                        |                         |       |
|                                |                           | Package             | 96                                       | 1050x710x1950  | 768                       | 832                        |                         |       |
|                                |                           |                     | 80                                       | 1050x710x1650  | 640                       | 700                        |                         |       |
|                                |                           |                     | 64                                       | 1050x710x1365  | 512                       | 564                        |                         |       |
|                                |                           | Sea package         | 80                                       | 1050x710x1650  | 640                       | 704                        |                         |       |
| 48                             | 1050x710x1075             |                     | 384                                      | 434            |                           |                            |                         |       |
| PSV160A<br>(H=170 mm)          | U160BLP                   | Package with crates | 54                                       | 1025x1155x1195 | 432                       | 543,6                      | 8,0                     |       |
|                                |                           |                     | 36                                       | 1025x1155x860  | 288                       | 377,8                      |                         |       |
|                                |                           | Package             | 96                                       | 1050x795x1650  | 768                       | 832                        |                         |       |
|                                |                           |                     | 80                                       | 1050x795x1650  | 640                       | 700                        |                         |       |
|                                |                           |                     | 64                                       | 1050x795x1075  | 512                       | 565                        |                         |       |
|                                |                           | Sea package         | 48                                       | 1050x795x1075  | 384                       | 435                        |                         |       |
|                                |                           |                     |  |                |                           |                            |                         |       |
| PS210V<br>(H=170 mm)           | U210B                     | Package with crates | 96                                       | 1255x1155x1420 | 691,2                     | 823,2                      | 7,2                     |       |
|                                |                           |                     | 72                                       | 1255x1155x1105 | 518,4                     | 626,4                      |                         |       |
|                                |                           | Package             | 100                                      | 1155x790x1520  | 720                       | 780                        |                         |       |
|                                |                           |                     | 80                                       | 1155x790x1260  | 576                       | 630                        |                         |       |
|                                |                           |                     | 60                                       | 1155x790x1000  | 432                       | 480                        |                         |       |
|                                |                           | Sea package         | 100                                      | 1155x790x1520  | 720                       | 784                        |                         |       |
| 80                             | 1155x790x1260             |                     | 576                                      | 633            |                           |                            |                         |       |
| 60                             | 1155x790x1000             | 432                 | 482                                      |                |                           |                            |                         |       |
| PS210V<br>(H=195 mm)           | ---                       | Package             | 100                                      | 1175x875x1505  | 720                       | 790,2                      | 7,2                     |       |
|                                |                           |                     | Sea package                              | 80             | 1155x865x1260             | 576                        |                         | 637   |
|                                |                           |                     |  | 60             | 1155x865x1000             | 432                        |                         | 486   |
| PS210D<br>PS210M<br>(H=170 mm) | U210B                     |                     | 100                                      | 1155x810x1470  | 820                       | 874                        | 8,2                     |       |
|                                |                           |                     | 80                                       | 1155x810x1220  | 656                       | 704,8                      |                         |       |
| PSV210D<br>(H=170 mm)          | U210BP                    | Package with crates | 54                                       | 1025x1155x1195 | 496,8                     | 608,4                      | 9,2                     |       |
|                                |                           |                     | 36                                       | 1025x1155x860  | 331,2                     | 421                        |                         |       |
|                                |                           | Package             | 96                                       | 1050x795x1950  | 883,2                     | 947,4                      |                         |       |
|                                |                           |                     | 80                                       | 1050x795x1650  | 736                       | 794,2                      |                         |       |
|                                |                           |                     | 64                                       | 1050x795x1365  | 588,8                     | 641,6                      |                         |       |
|                                |                           | Sea package         | 80                                       | 1050x795x1650  | 736                       | 799                        |                         |       |
| 48                             | 1050x795x1075             |                     | 441,6                                    | 489,6          |                           |                            |                         |       |
| PSV210D<br>(H=195 mm)          | ---                       | Package with crates | 45                                       | 1105x1025x1195 | 414                       | 523,2                      | 9,2                     |       |
|                                |                           |                     | Package                                  | 80             | 1050x1055x1650            | 736                        |                         | 803,2 |
|                                |                           |                     | Sea package                              | 48             | 1050x1070x875             | 441,6                      |                         | 500,4 |
| PS300V<br>(H=195 mm)           | U300B                     | Package             | 60                                       | 1070x700x1660  | 600                       | 655,6                      | 10                      |       |
|                                |                           |                     | 36                                       | 1070x700x1080  | 360                       | 404,4                      |                         |       |
|                                |                           | Sea package         | 60                                       | 1070x700x1660  | 600                       | 655,6                      |                         |       |
|                                |                           |                     | 36                                       | 1070x700x1080  | 360                       | 404,4                      |                         |       |
|                                |                           |                     | 48                                       | 1150x750x1200  | 480                       | 530                        |                         |       |
|                                |                           |                     | 24                                       | 1150x750x1000  | 240                       | 278,8                      |                         |       |
| 72                             | 1255x1005x1100            | 720                 | 781,2                                    |                |                           |                            |                         |       |

| Truck                     |                             |            | 20 foot container         |                             |            | 40 foot container         |                             |            |
|---------------------------|-----------------------------|------------|---------------------------|-----------------------------|------------|---------------------------|-----------------------------|------------|
| Quantity of packages, pcs | Quantity of insulators, pcs | Weight, kg | Quantity of packages, pcs | Quantity of insulators, pcs | Weight, kg | Quantity of packages, pcs | Quantity of insulators, pcs | Weight, kg |
| 26                        | 2600                        | 19955      |                           |                             |            |                           |                             |            |
| 26                        | 1980                        | 19826      | 10                        | 900                         | 8705       | 22                        | 1980                        | 19151      |
| 16                        |                             |            | 10                        |                             |            | 22                        |                             |            |
| 28                        | 2240                        | 19600      |                           |                             |            |                           |                             |            |
|                           |                             |            |                           |                             |            | 18                        | 2784                        | 24824      |
|                           |                             |            | 32                        | 1536                        | 13888      | 28                        |                             |            |
| 26                        | 1404                        | 19800      | 20                        | 1080                        | 10500      | 44                        | 2376                        | 22900      |
| 15                        | 540                         |            |                           |                             |            |                           |                             |            |
| 28                        | 2240                        | 19600      |                           |                             |            |                           |                             |            |
|                           |                             |            | 28                        | 1344                        | 12180      | 56                        | 2688                        | 24360      |
| 32                        | 2304                        | 20044      | 16                        | 1152                        | 10150      | 36                        | 2592                        | 22700      |
| 25                        | 2500                        | 19500      |                           |                             |            |                           |                             |            |
|                           |                             |            | 14                        | 1960                        | 15610      | 55                        | 3300                        | 26510      |
|                           |                             |            | 14                        |                             |            |                           |                             |            |
| 25                        | 2500                        | 19755      |                           |                             |            |                           |                             |            |
|                           |                             |            | 12                        | 1680                        | 13476      | 52                        | 3120                        | 25272      |
|                           |                             |            | 12                        |                             |            |                           |                             |            |
| 23                        | 2300                        | 20102      |                           |                             |            |                           |                             |            |
| 26                        | 1404                        | 19607      | 20                        | 1080                        | 11000      | 44                        | 2376                        | 24100      |
| 9                         | 324                         |            |                           |                             |            |                           |                             |            |
| 25                        | 2000                        | 19855      |                           |                             |            |                           |                             |            |
|                           |                             |            | 28                        | 1344                        | 12852      | 56                        | 2688                        | 25704      |
| 24                        | 1920                        | 19277      |                           |                             |            |                           |                             |            |
|                           |                             |            | 24                        | 1152                        | 11040      | 52                        | 2496                        | 23920      |
| 30                        | 1800                        | 19530      |                           |                             |            | 16                        | 2256                        | 25050      |
|                           |                             |            | 32                        | 1152                        | 13000      | 36                        |                             |            |
|                           |                             |            |                           |                             |            | 16                        | 2256                        | 25050      |
|                           |                             |            | 32                        | 1152                        | 13000      | 36                        |                             |            |
|                           |                             |            | 14                        | 3150                        | 13450      | 60                        | 6000                        | 25700      |
|                           |                             |            | 14                        |                             |            |                           |                             |            |
|                           |                             |            | 18                        | 1296                        | 9340       | 36                        | 2592                        | 18540      |

| Types of Insulators (GOST) | Types of Insulators (IEC) | Types of package    | Quantity of insulators per package, pcs. | Dimensions, mm | Netto weight/ package, kg | Gross weight/ package, kg. | Weight of insulator, kg |
|----------------------------|---------------------------|---------------------|--|----------------|---------------------------|----------------------------|-------------------------|
| PS240V<br>(H=170 mm)       | U240B                     | Package             | 100                                      | 1165x775x1560  | 710                       | 777,8                      | 7,1                     |
|                            |                           |                     | 80                                       | 1165x775x1290  | 568                       | 687                        |                         |
|                            |                           |                     | 60                                       | 1165x775x990   | 426                       | 523                        |                         |
|                            |                           | Sea package         | 100                                      | 1165x775x1560  | 710                       | 851                        |                         |
|                            |                           |                     | 80                                       | 1165x775x1290  | 568                       | 687                        |                         |
|                            |                           |                     | 60                                       | 1165x775x990   | 426                       | 523                        |                         |
| PSD100V<br>(H=127 mm)      | ---                       | Package             | 100                                      | 1175x740x1705  | 510                       | 596,8                      | 5,1                     |
|                            |                           |                     | 60                                       | 1175.x740x1105 | 306                       | 367                        |                         |
|                            |                           | Sea package         | 100                                      | 1175x740x1705  | 510                       | 592                        |                         |
| PSD100V<br>(H=146 mm)      | ---                       | Package             | 100                                      | 1175x810x1705  | 510                       | 602,2                      | 5,1                     |
|                            |                           |                     | 60                                       | 1175.x810x1105 | 306                       | 371                        |                         |
|                            |                           | Sea package         | 100                                      | 1175x810x1705  | 510                       | 597                        |                         |
| U120BA<br>(H=127 mm)       | ---                       | Package with crates | 42                                       | 970x810x1370   | 218,4                     | 286                        | 5,2                     |
|                            |                           |                     | 28                                       | 970x810x965    | 145,6                     | 189,6                      |                         |
| U120BA<br>(H=146 mm)       | ---                       | Package with crates | 42                                       | 1085x810x1370  | 218,4                     | 292,8                      | 5,2                     |
|                            |                           |                     | 28                                       | 1085x810x965   | 145,6                     | 203,8                      |                         |
| ShS 10 ED                  | ---                       | Package             | 440                                      | 1140x970x2160  | 968                       | 1146                       | 2,2                     |
|                            |                           |                     | 400                                      | 1140x970x1980  | 880                       | 1046                       |                         |
|                            |                           |                     | 320                                      | 1140x970x1630  | 704                       | 846                        |                         |
| ShS 20 ED                  | ---                       | Package             | 270                                      | 1085x960x2027  | 828,9                     | 969                        | 3,07                    |

| Truck                     |                             |            | 20 foot container         |                             |            | 40 foot container         |                             |            |
|---------------------------|-----------------------------|------------|---------------------------|-----------------------------|------------|---------------------------|-----------------------------|------------|
| Quantity of packages, pcs | Quantity of insulators, pcs | Weight, kg | Quantity of packages, pcs | Quantity of insulators, pcs | Weight, kg | Quantity of packages, pcs | Quantity of insulators, pcs | Weight, kg |
| 25                        | 2500                        | 19445      |                           |                             |            | 30                        | 3000                        | 25630      |
|                           |                             |            | 14                        | 1960                        | 17050      |                           |                             |            |
|                           |                             |            | 14                        |                             |            |                           |                             |            |
|                           |                             |            |                           |                             |            | 30                        | 3000                        | 25630      |
|                           |                             |            | 14                        | 1960                        | 17050      |                           |                             |            |
|                           |                             |            | 14                        |                             |            |                           |                             |            |
| 33                        | 3300                        | 19694,4    | 11                        | 1100                        | 6650       | 26                        | 2600                        | 15470      |
|                           |                             |            |                           |                             |            |                           |                             |            |
|                           |                             |            | 11                        | 1100                        | 6650       | 26                        | 2600                        | 15470      |
| 32                        | 3200                        | 19270,4    | 11                        | 1100                        | 6740       | 24                        | 2400                        | 14480      |
|                           |                             |            |                           |                             |            |                           |                             |            |
|                           |                             |            | 11                        | 1100                        | 6740       | 24                        | 2400                        | 14480      |
| 41                        | 2870                        | 19868,6    |                           |                             |            |                           |                             |            |
| 41                        |                             |            |                           |                             |            |                           |                             |            |
| 36                        | 2520                        | 17877,6    |                           |                             |            |                           |                             |            |
| 36                        |                             |            |                           |                             |            | 56                        | 1568                        | 11424      |
|                           |                             |            |                           |                             |            |                           |                             |            |
| 19                        | 7600                        | 19351,5    | 12                        | 4800                        | 12580      | 24                        | 9600                        | 25200      |
| 22                        | 7040                        | 18612      | 12                        | 3840                        | 10180      | 24                        | 7680                        | 20320      |
| 20                        | 5400                        | 19380      | 10                        | 2700                        | 9806       | 24                        | 6480                        | 23328      |





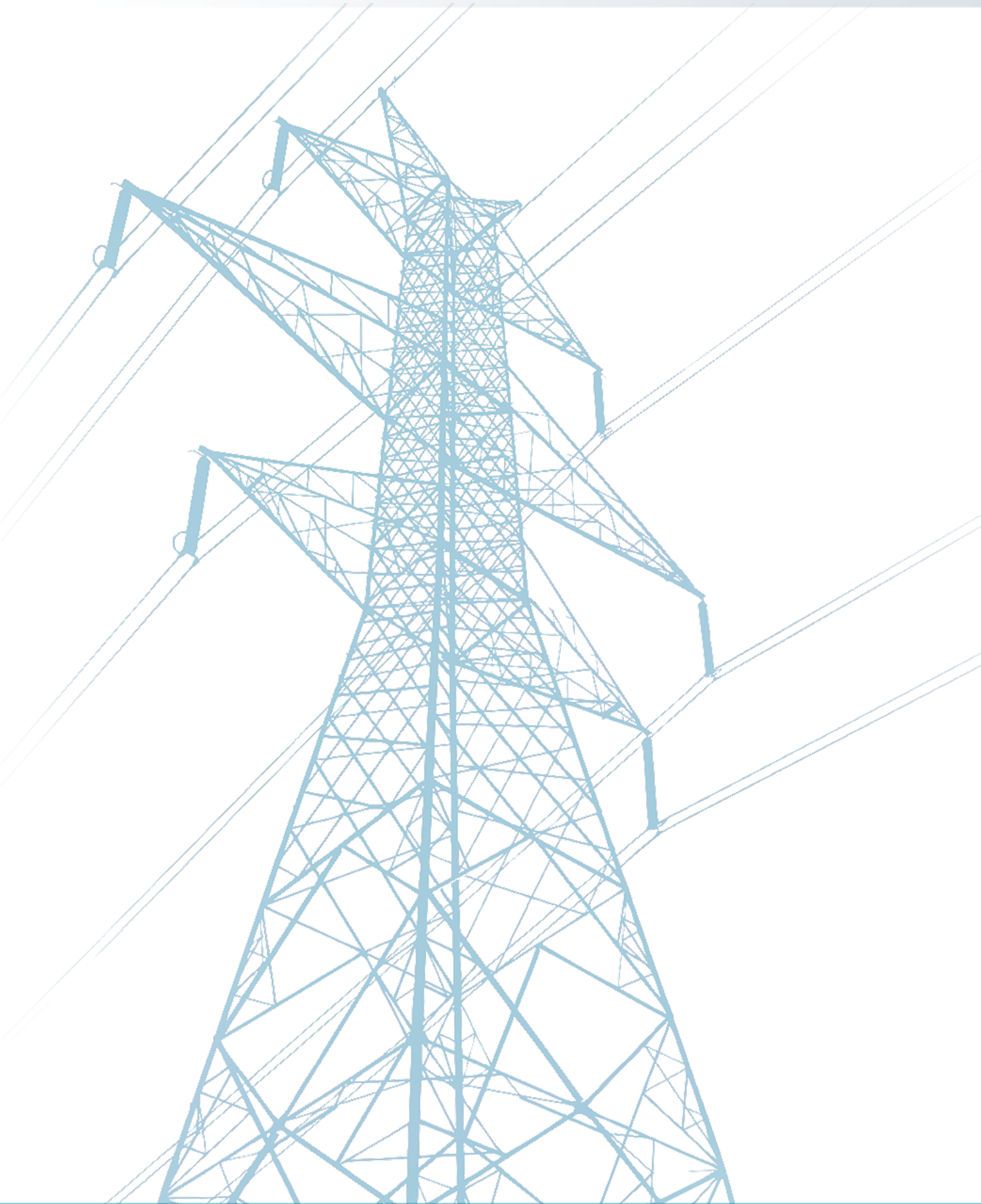

«UMEK», STROITELEY 1B, YUZHNOURALSK, 457040 RUSSIA  
TEL: 7 (351) 344-05-33  
SALES@UMEK.PRO  
WWW.UMEK.PRO